

## MP909E and H Pneumatic Damper Actuators

### SPECIFICATION DATA



### FEATURES

- Low friction shaft bearing
- Close tolerance on operating range and stroke
- Versatile mounting and connecting hardware
- Cost efficient mounting to Honeywell dampers
- Nonoverlapping spring ranges for sequencing
- Corrosion resistant materials
- Reliable—long life
- Models available for use with UL classified leakage rated (smoke) dampers

### GENERAL

The MP909E and H Pneumatic Damper Actuators control dampers, variable volume terminal units, and mixing boxes. The MP909H is an MP909E with a positive positioner.



## SPECIFICATIONS

### Models:

- MP909E Actuator without positioner
- MP909H Actuator with positioner

### Maximum Safe Air Pressure:

MP909E: 29 psi (200 kPa)

MP909H: 25 psi (172 kPa), limited by positioner

### Operating Range:

MP909E: See following table

MP909H: Span of 3, 5, or 10 psi (21, 34, or 69 kPa), nonadjustable. Provided with 10 psi feedback spring; 5 psi feedback spring included; 3 psi feedback spring available

### Startpoint Pressure (MP909H):

Adjustable 1.5 to 13 psi (10.3 to 90 kPa)

### Ambient Temperature Range:

MP909E: -28 to 160F (-33 to 70C)

MP909H: -20 to 160F (-29 to 70C), limited by positioner

### Mounting:

Trunnion and right angle bracket

### Net Force Exerted:

Model	Operating Range psi (kPa)	Stroke in. (mm)	Net Force in Pounds (N) Exerted at Various Pressures		
			0 psi (0 kPa)	18 psi (124 kPa)	20 psi (140 kPa)
MP909E	3-13 (21-90)	4.0 (100)	19.8 (88)	33 (147)	46.2 (206)
	5-10 (34-69)		33 (147)	53 (236)	66 (294)
	2.5-6.5 (17-45)	3.1 (80)	16.5 (73)	76 (338)	89 (396)
	5-10 (34-69)		33 (147)	53 (236)	66 (294)
9-13 (62-90)	59.4 (264)		33 (147)	46.2 (206)	
MP909H	All spans <sup>1</sup>	4.0 (100)	33 (147)	53 (236)	66 (294)

<sup>1</sup>MP909H has 5-10 psi (34-69 kPa) operating spring range.

### Air Connections:

MP909E: Combination 5/32-in. (4 mm) and 1/4-in. (6 mm) push-on barb

MP909H:

Positioner: 5/32-in. (4 mm) push-on barb (pilot), 1/4-in. (6 mm) push-on barb (main and branch)

Actuator: combination 5/32-in (44 mm) and 1/4-in. (6 mm) push-on barb

UL listed actuators: Special high temperature plastic tubing pigtails that allow connection to 1/4-in. (6 mm) O.D. copper tubing

### Diaphragm:

Neoprene, rolling type

Effective area 6.6 in<sup>2</sup> (40 cm<sup>2</sup>)

### Body Material and Finish:

Corrosion resistant aluminum alloy

### Air Consumption:

MP909E: Zero

MP909H: 0.021 scfm (9.9 ml/sec)

**Dimensions:**

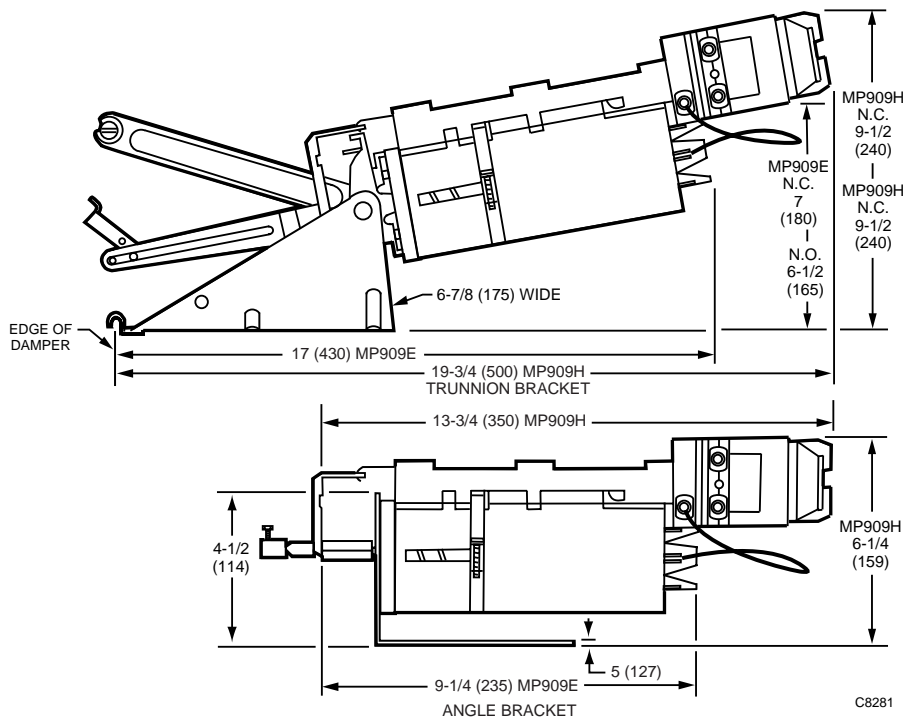

**UL Listed:**

Models Available: MP909E: 5 to 10 psi (34 to 69 kPa)  
 UL Restrictions: UL listing applies only when used with UL classified Honeywell SD series leakage rated dampers  
 Mainline Pressure Limits: 15 psi (103 kPa) minimum; 25 psi (172 kPa) maximum

**Damper Limitations:**

- D640SD, D641SD: See 77-5129
- D644SD, D645SD: See 77-5140

**Accessories:**

- Feedback spring kit for 3 psi span (MP909H): 14004509-001 (10 springs per kit)
- Positioner Kit to convert MP909E 5 to 10 psi to MP909H (includes 3, 5, and 10 psi feedback spring): 14004137-001

**Damper A and B Dimensions**

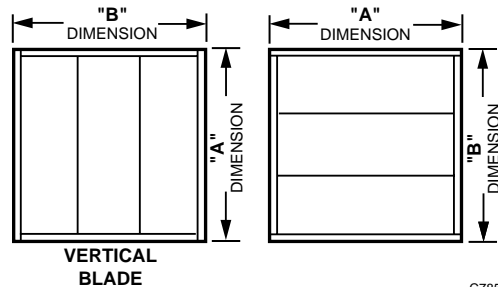

**EXAMPLE:**

Damper Model: D641  
 Duct Dimension: 62 inches (A dimension) x 20 inches (B dimension)  
 Actuator: MP909E  
 Operating Range: 5 to 10 psi (34 to 69 kPa)  
 Type of Operation: Modulating Service  
 Main Air Pressure: 13 psi (90 kPa)  
 The 62-inch A dimension requires two damper sections (48 inches maximum per section). Multiplying the B dimension (20 inches) by two equals 40 inches of total B dimension. The Maximum Damper Load Rating Table shows that one MP909E can operate up to 33 inches of damper. Two MP909Es are required in this example.

MP909E AND H PNEUMATIC DAMPER ACTUATORS

**Damper Load Rating (See Following Table):**

Damper load ratings for Honeywell Moduflow Dampers (non-UL Listed models) are calculated by multiplying the B dimension of each section by the number of sections required.

**Approvals:**

MP918B (all models): UL Recognized Component, Category EMKU2, File No. R18118, Mainline -25 psi maximum

Damper Model	Actuator Model	Operating Range psi (kPa)	Modulating Service		2-Position Service
			Main Air Pressure 13 psi (80 kPa) for B Dimension in. (mm)	Main Air Pressure 18 psi (124 kPa) for B Dimension in. (mm)	Main Air Pressure 18 psi (124 kPa) for B Dimension in. (mm)
D640	MP909E	3-13 (21-90)	—	33 (835)	36 (910)
D641		5-10 (34-69) <sup>3</sup>	33 (835)	33 (835)	60 (1520)
		2.5-6.5 (17-45)	27 (685) <sup>1</sup>	27 (685) <sup>1</sup>	27 (685) <sup>1</sup>
		9-13 (62-90)	—	29 (735)	49 (1240)
	MP909H <sup>4</sup>	N.A.	40 (1010)	67 (1700)	67 (1700)
D642	MP909E	3-13 (21-90)	—	27 (685)	29 (735)
D643		5-10 (34-69) <sup>3</sup>	27 (685)	27 (685)	49 (1240)
D644		2.5-6.5 (17-45)	22 (555) <sup>2</sup>	22 (555) <sup>2</sup>	22 (555) <sup>2</sup>
D645		9-13 (62-90)	—	27 (685)	40 (1010)
	MP909H <sup>4</sup>	N.A.	33 (835)	60 (1520)	60 (1520)

<sup>1</sup>With normally closed linkage having 81-degree rotation. For 90-degree rotation, use 20 inches (505 mm).

<sup>2</sup>With normally closed linkage having 81-degree rotation. For 90-degree rotation, use 17 inches (430 mm).

<sup>3</sup>Applies to 4-in. stroke models only.

<sup>4</sup>Rating also applies to MP909E 5 to 10 psi (34-69 kPa) slaves used with MP909H.

By using this Honeywell literature, you agree that Honeywell will have no liability for any damages arising out of your use or modification to, the literature. You will defend and indemnify Honeywell, its affiliates and subsidiaries, from and against any liability, cost, or damages, including attorneys' fees, arising out of, or resulting from, any modification to the literature by you.

**Home and Building Control**  
Honeywell Inc.

**Home and Building Control**  
Honeywell Limited-Honeywell Limitée

**Honeywell Asia Pacific Inc.**

**Honeywell Latin American Division**

**Honeywell Europe S.A.**

**Honeywell**

*Helping You Control Your World*

